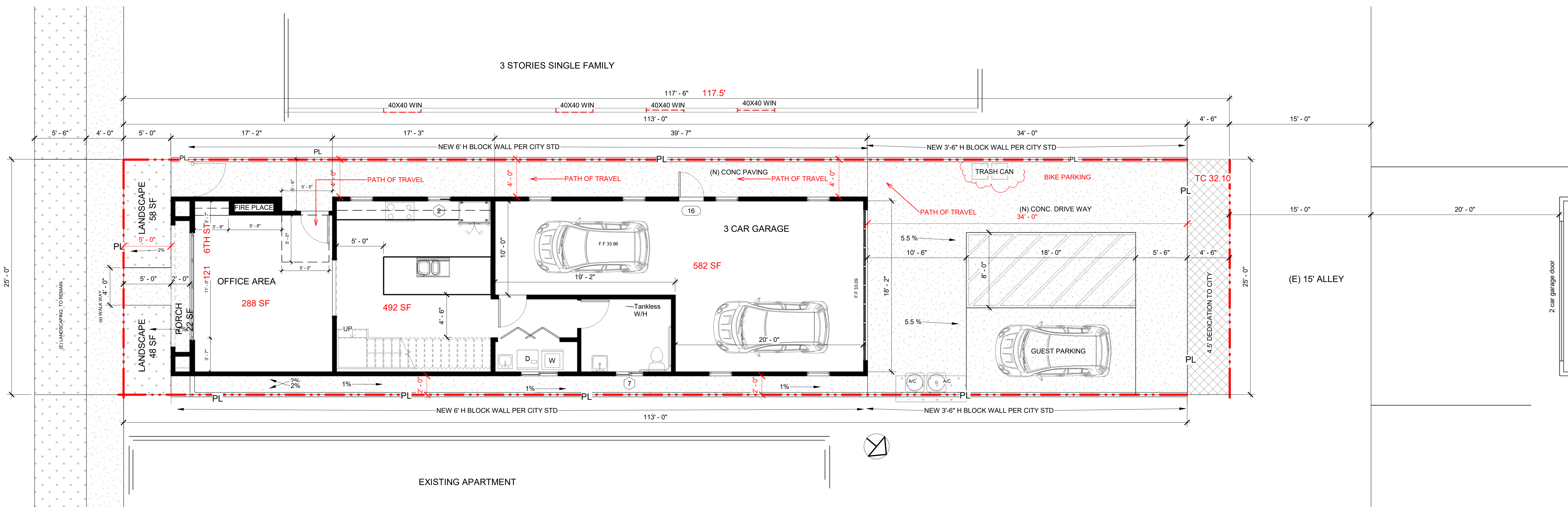

ENGINEER:  
BEN PHAN P.E. 714-251-4537  
11541 ELIZABETH ST, GARDEN GROVE, CA

DESIGNER:  
FL DESIGN GROUP, 714-414-5636  
14211 RIATA ST, WESTMINSTER, CA 92683

**FL DESIGN GROUP**  
Residential & Commercial Design  
14211 Riata St, Westminster, CA. 92683  
Tel: 714-414-5636

① SITE PLAN  
3/16" = 1'-0"

**CUSTOM HOMES**  
Owner: Thomas Nguyen  
121 6th street, Huntington Beach, CA 92648

**RESTRICTIVE NOTICE**  
THESE DESIGNS, DRAWINGS & SPECIFICATIONS ARE THE EXCLUSIVE PROPERTY OF FL DESIGN GROUP AND ALL INFORMATION SHOWN IS CONFIDENTIAL TO ALL RECIPIENTS AND NO PART OF THESE DRAWINGS CAN BE COPIED, TRANSFERRED, OR REPRODUCED WITHOUT WRITTEN CONSENT OF FL DESIGN GROUP.

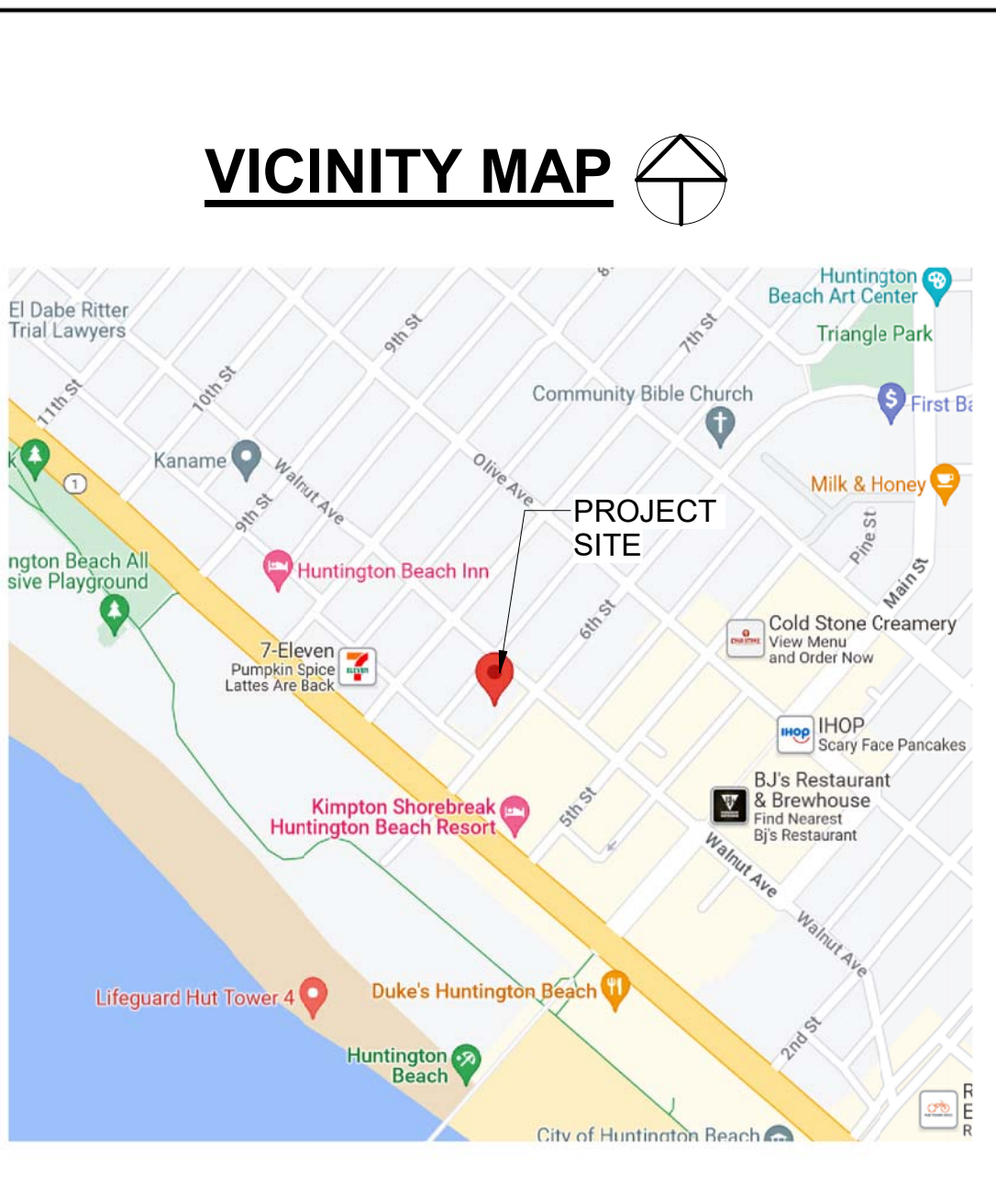

**BUILDING DATA**

**LEGAL DESCRIPTION:** HUNTINGTON BEACH, COUNTY OF ORANGE

**ASSESSOR'S NUMBER:** 024-151-06

**EXISTING ZONE:** GROUP SP 5 - MIXED USE - RESIDENTIAL

**OCC GROUP:** R-3 (SINGLE FAMILY) / U (GARAGE)

**TYPE OF CONST.:** TYPE V-B, 3 STORY BUILDING - FULLY FIRE SPRINKLERS

**SCOPE OF WORK:** DEMOLISH EXISTING HOUSE AND CONSTRUCT NEW 3 STORIES CUSTOM HOUSE WITH ATTACHED 3 CAR GARAGE

**NOTES:**

- FIRE SPRINKLERS TO BE SUBMITTED AS SEPARATED PERMIT & APPROVED BEFORE FRAMING INSPECTION - APPROVED FIRE SPRINKLER PLAN SHALL BE PROVIDED AT THE SITE AT THE TIME OF FRAMING INSPECTION
- ALL WALLS AND FENCING REQUIRE SEPARATE PERMIT
- SEPARATED GRADING TO BE SUBMITTED & APPROVED PRIOR TO ISSUANCE OF BUILDING PERMIT
- TRUSS CALLS TO BE SUBMITTED AS SEPARATED PERMIT (DEFERRED SUBMITTAL ITEM SHALL BE REVIEWED AND APPROVED BY THE REGISTERED DESIGN PROFESSIONAL AND SUBMITTED TO THE BUILDING DEPARTMENT FOR APPROVAL)

**APPLICABLE BUILDING CODES:**

LOCALLY ADOPTED BUILDING CODE AND APPLICABLE CALIFORNIA ADMINISTRATIVE CODE(S)

2022 CRC, CBC, CMC, CEC, CPC, CFC

2022 CALIFORNIA ENERGY CODE, 2022 CALIFORNIA GREEN BUILDING CODE

HB MUNICIPAL 17.05 & HB250 230.84

- EXISTING LOT SIZE : 2,97.5 SF

- NEW LOT SIZE AFTER DEDICATION : 2,825 SF

OFFICE : 284 SF

1ST FLR : 492 SF

2ND FLR : 1,102 SF

3RD FLOOR : 925 SF

3 CAR GARAGE : 582 SF

2ND AND 3RD FLR'S DECK : 784 SF

ROOF DECK : 968 SF

TOTAL AREA : 2803 SF

OVERHANG : 38 SF

FOOT PRINT : 1398 SF

- LOT COVERAGE: 1398/2825 = 49.4 %

- LOT COVERAGE AT FRONT YARD 106/125 = 85 % > 70% - OK

- LANDSCAPING PERCENTAGE 20/125 = 16%

SUBJECT	CODE SECTION	REQUIRED	PROPOSED
FRONT SET BACK		1 - 5 FEET	5'-0"
REAR SET BACK		10'	34'-0" ( after city dedication)
SIDE SET BACK		0'	3'
LOT COVERAGE		50 %	49.4 %
MAX HEIGHT		35'	33'-6" H ABOVE FLOOR FINISH 35'-0" ABOVE TOP OF CURB
PARKING		2 COVERED PARKING FOR 4 BED RM	3 COVERED PARKING for 4 BED RM
MAX FLOOR AREA		MAX 2827 SF	2700 SF

**LEGAL DESCRIPTION:**  
LOT 21 BLOCK 106 OF MAP OF HUNTINGTON BEACH, THE CITY OF HUNTINGTON BEACH, COUNTY OF ORANGE, STATE OF CALIFORNIA, AS PER MAP RECORDED IN BOOK 3, PAGE 43, OF MISCELLANEOUS MAPS, RECORDS IN THE OFFICE OF THE COUNTY RECORDER OF SAID ORANGE COUNTY, CALIFORNIA.  
ASSESSORS NUMBER: 024-151-06

Project No: 71-01  
Date: 03-25-2024

SITE PLAN

A1

**RESTRICTIVE NOTICE**  
 THESE DESIGNS, DRAWINGS & SPECIFICATION ARE THE EXCLUSIVE PROPERTY OF FL DESIGN GROUP AND ALL INFORMATION SHOWN IS CONFIDENTIAL TO ALL RECIPIENTS AND NO PART OF THESE DRAWINGS CAN BE COPIED, TRANSFERRED, OR REPRODUCED WITHOUT WRITTEN CONSENT OF FL DESIGN GROUP.

Project No: 71-01  
 Date: 03-25-2024

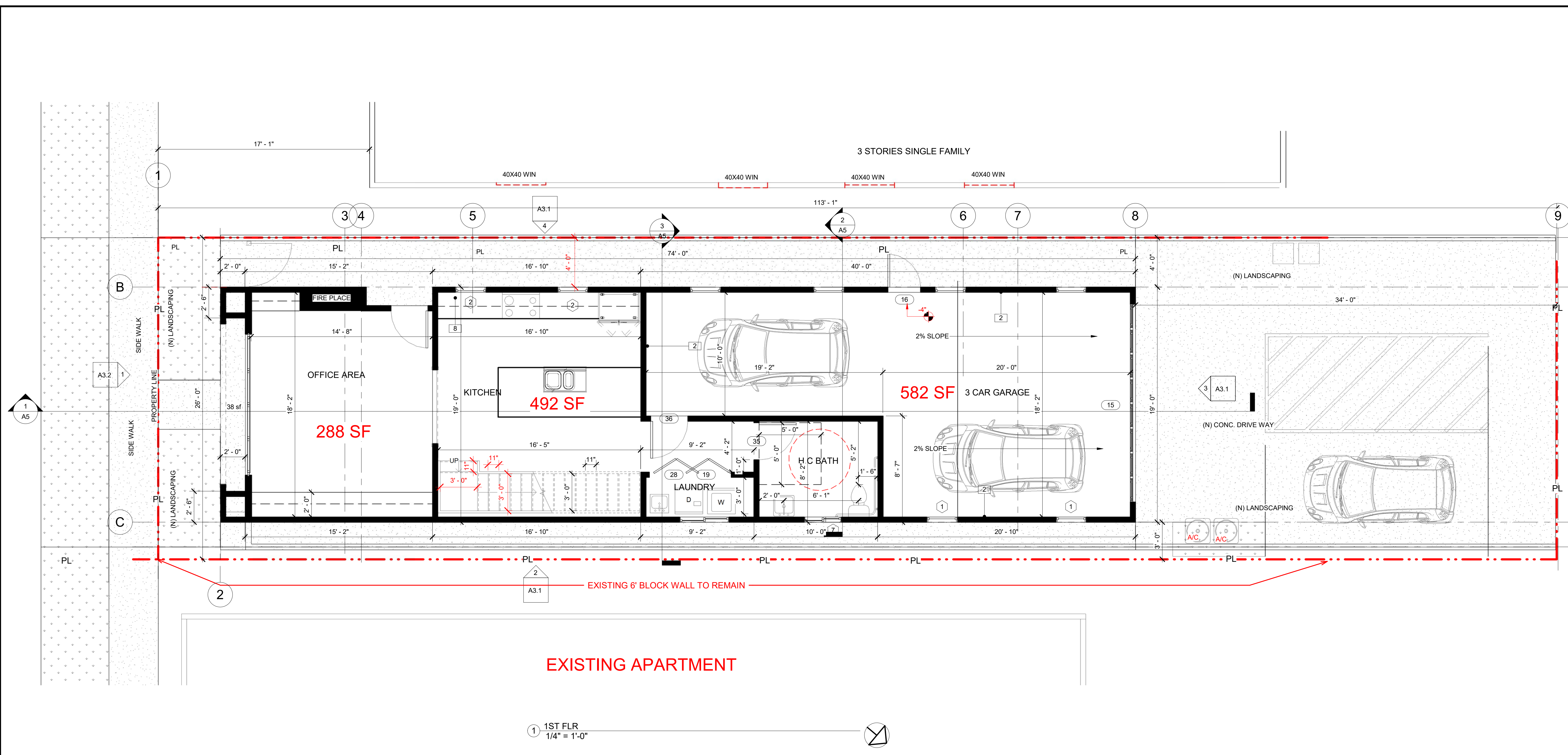

**EXISTING APARTMENT**

1 1ST FLR  
 1/4" = 1'-0"

**FLOOR PLAN SYMBOLS**

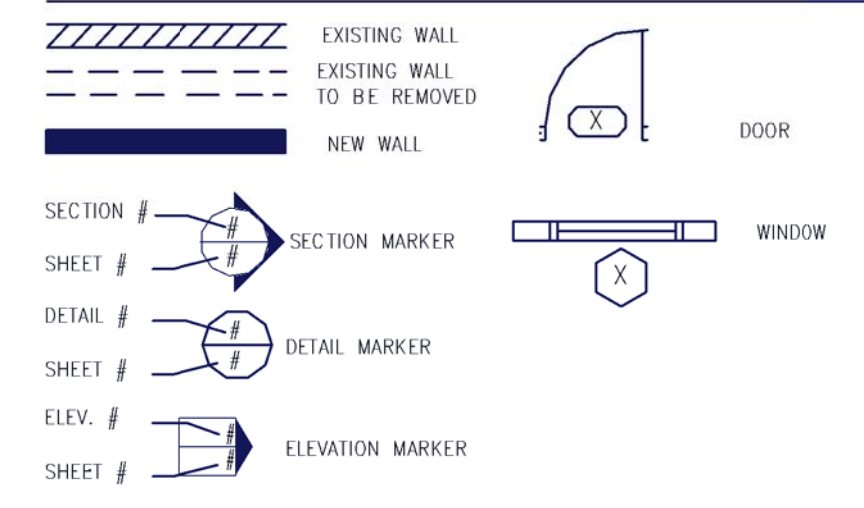

- FLOOR PLAN NOTE:**
- WOOD FRAME STAIR, 7.75" RISER, 11" TREAD- WITH NOSING SHALL BE 3/4" - 1 1/4" MAXIMUM. SEE STRUCTURE PLAN
  - 1 HR FIRED RATED WALL WITH 5/8" TYPE X GYPDUM BD BOTHSIDE AT WALL, AT CEILING AND AROUND BEAM
  - NEW 4" CONC. PAD
  - GUARD RAIL 42" HIGH
  - HANDRAIL 34"x38" MAX W/ OPENING RAILS MAX 4" O.C
  - PROVIDE 1 HR FIRED RATED WALL WITH 5/8" DRYWALL UNDER STAIR
  - INSTALL WATERPROOFING PLI-DECK SYSTEM AT BALCONY- ESR-2097 SEE 2/A-7
  - Dimplex 39-inch Purifire Electric Fireplace ( NO GAS) APPLIANCE
  - 3" PVC DRAIN PIPE W/ OVER FLOW DRAIN, DET 3/A7
  - ELEVATOR BY GARAVENTA LIFT- WITH CLEAR CAB SIZE 36" X 48"- CLEAR INTERIOR SIZE 55" X 55"- (SEE A-8 FOR ELEVATOR SPECIFICATION)- PROVIDE 2.5"x7.5" 1.3E LSL FULL HEIGHT STUD (29H)- SEE STRUCTURE FOR DETAIL

- BATHROOM NOTES:**
- PROVIDE WATER RESISTANT CEMENT BACKING BOARD AS BASE FOR TILE OR WALL PANELS FOR TUB OR SHOWER ENCLOSURES OR WATER CLOSET COMPARTMENT WALLS
  - ANTI SCALDING TUB SHOWER VALVES REQUIRED
  - PROVIDE NON ABSORBENT MATERIAL 72" ABOVE DRAIN
  - PROVIDE 20 AMPS DELICATE CIRCUIT @ BATHROOM
  - PROVIDE COVERING SHALL BE CEMENT BOARD, TILE OR APPROVED MATERIALS OTHER THAN STRUCTURAL ELEMENTS SHALL BE MOISTURE RESISTANT, GLASS ENCLOSURE DOORS AND PANELS MUST BE LABELED CATEGORY II, SWING DOOR OUTWARD, NET AREA OF SHOWER RECEPTOR SHALL BE NOT LESS THAN 1,024 SQ. IN OF FLOOR AREA, AND ENCOMPASS 30 INCH DIAMETER CIRCLE. (807.1.3,2407, AND PC412.0)
  - SHOWER AND BATHTUB DOORS AND ENCLOSURES. GLAZING IN ANY PORTION OF A BUILDING WALL ENCLOSING HOT TUBS, WHIRLPOOLS, SAUNAS, STEAM ROOMS, BATH TUBS AND SHOWER WHERE THE BOTTOM EXPOSED EDGE OF THE GLAZING IS LESS THAN 60" ABOVE A STANDING SURFACE AND DRAIN INLET.
  - THE DWELLING SHALL HAVE WATER CLOSETS WHICH USE NO MORE THAN 1.25 GALLONS PER FLUSH

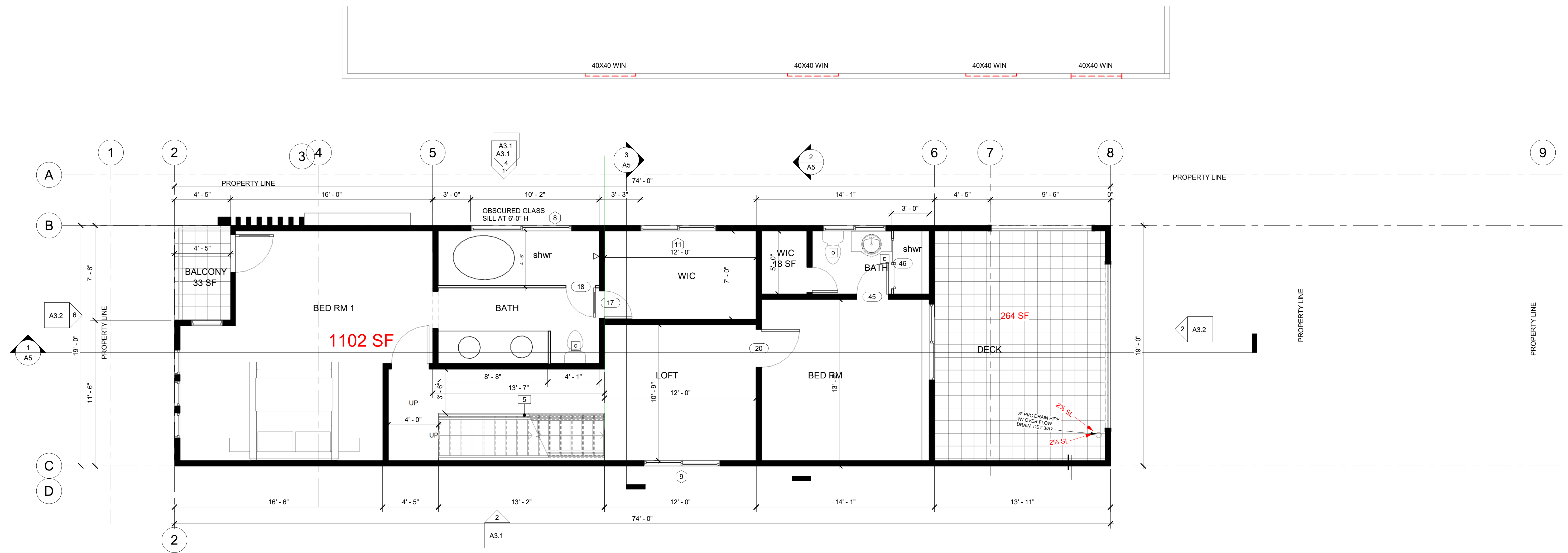

**EXISTING APARTMENT**

1 2nd Flr  
 1/4" = 1'-0"

**FLOOR PLAN SYMBOLS**

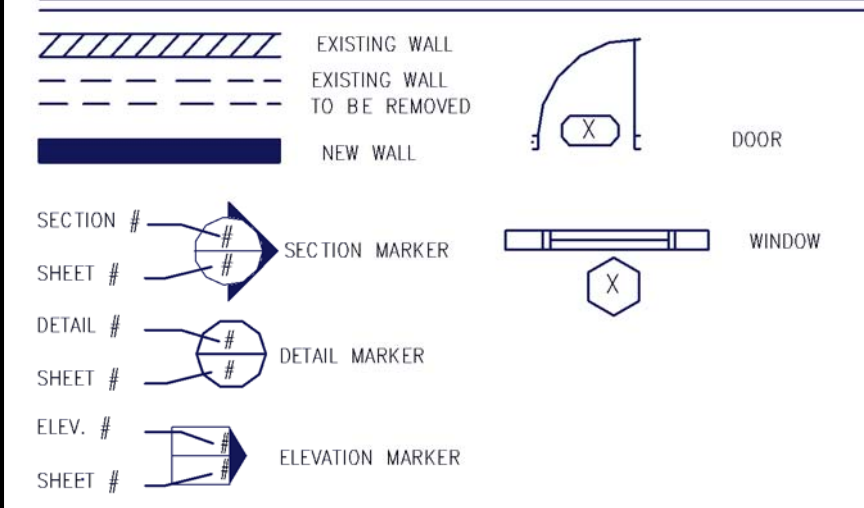

- FLOOR PLAN NOTE:**
- 1- WOOD FRAME STAIR, 7.75" RISER, 11" TREAD- WITH NOSING SHALL BE 3/4" -1-1/4" MAXIMUM, SEE STRUCTURE PLAN
  - 2- 1 HR FIRED RATED WALL WITH 5/8" TYPE X GYPDUM BD BOTHSIDE AT WALL, AT CEILING AND AROUND BEAM
  - 3- NEW 4" CONC. PAD
  - 4- GUARD RAIL 42" HIGH
  - 5- HANDRAIL 34"-38" MAX W/ OPENING RAILS MAX 4" O.C
  - 6- PROVIDE 1 HR FIRED RATED WALL WITH 5/8" DRYWALL UNDER STAIR
  - 7- INSTALL WATERPROOFING PLI-DECK SYSTEM AT BALCONY- ESR-2097 SEE 2/A-7
  - 8- Dimplex 39-Inch Purifire Electric Fireplace ( NO GAS) APPLIANCE
  - 9- 3" PVC DRAIN PIPE W/ OVER FLOW DRAIN, DET 3/A7
  - 10- ELEVATOR BY GARAVENTA LIFT- WITH CLEAR CAB SIZE 36" X 48"- CLEAR INTERIOR SIZE 55" X 55"- (SEE A-8 FOR ELEVATOR SPECIFICATION)- PROVIDE 2.5"x7.5" 1.3E LSL FULL HIGHT STUD (29"H)- SEE STRUCTURE FOR DETAIL

- BATHROOM NOTES:**
- PROVIDE WATER RESISTANT CEMENT BACKING BOARD AS BASE FOR TILE OR WALL PANELS FOR TUB OR SHOWER ENCLOSURES OR WATER CLOSET COMPARTMENT WALLS
  - ANTI SCALDING TUB SHOWER VALVES REQUIRED
  - PROVIDE NON ABSORBENT MATERIAL 72" ABOVE DRAIN
  - PROVIDE 20 AMPS DELICATE CIRCUIT @ BATHROOM
  - PROVIDE COVERING SHALL BE CEMENT BOARD, TILE OR APPROVED EQUAL TO 72 INCHES ABOVE DRAIN AT SHOWERS OR TUB WITH SHOWER MATERIALS OTHER THAN STRUCTURAL ELEMENTS SHALL BE MOISTURE RESISTANT, GLASS ENCLOSURE DOORS AND PANELS MUST BE LABELED CATEGORY II, SWING DOOR OUTWARD, NET AREA OF SHOWER RECEPTOR SHALL BE NOT LESS THAN 1,024 SQ. IN OF FLOOR AREA, AND ENCOMPASS 30 INCH DIAMETER CIRCLE. (807.1.3.2407, AND PC412.0)
  - SHOWER AND BATHTUB DOORS AND ENCLOSURES. GLAZING IN ANY PORTION OF A BUILDING WALL ENCLOSING HOT TUBS, WHIRLPOOLS, SAUNAS, STEAM ROOMS, BATH TUBS AND SHOWER WHERE THE BOTTOM EXPOSED EDGE OF THE GLAZING IS LESS THAN 60" ABOVE A STANDING SURFACE AND DRAIN INLET
  - THE DWELLING SHALL HAVE WATER CLOSETS WHICH USE NO MORE THAN 1.25 GALLONS PER FLUSH

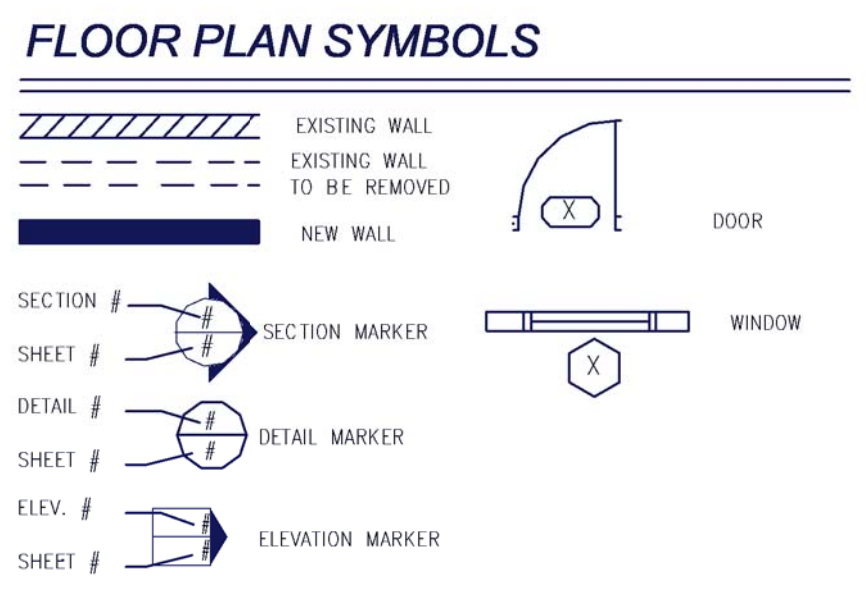

- FLOOR PLAN NOTE:**
- 1- WOOD FRAME STAIR, 7.75" RISER, 11" TREAD- WITH NOSING SHALL BE 3/4" - 1-1/4" MAXIMUM. SEE STRUCTURE PLAN
  - 2- 1 HR FIRED RATED WALL WITH 5/8" TYPE X GYPDUM BD BOTHSIDE AT WALL, AT CEILING AND AROUND BEAM
  - 3- NEW 4" CONC. PAD
  - 4- GUARD RAIL 42" HIGH
  - 5- HANDRAIL 34" X 38" MAX W/ OPENING RAILS MAX 4" O.C
  - 6- PROVIDE 1 HR FIRED RATED WALL WITH 5/8" DRYWALL UNDER STAIR
  - 7- INSTALL WATERPROOFING PLI-DECK SYSTEM AT BALCONY- ESR-2097 SEE 2/A-7
  - 8- Dimplex 39-Inch Purifire Electric Fireplace ( NO GAS) APPLIANCE
  - 9- 3" PVC DRAIN PIPE W/ OVER FLOW DRAIN, DET 3/4"
  - 10- ELEVATOR BY GARAVENTA LIFT- WITH CLEAR CAB SIZE 36" X 48"- CLEAR INTERIOR SIZE 55" X 55"- (SEE A-8 FOR ELEVATOR SPECIFICATION)- PROVIDE 2.5"x7.5" 1.3E LSL FULL HIGHT STUD (29H)- SEE STRUCTURE FOR DETAIL

2 3rd Floor  
 1/4" = 1'-0"

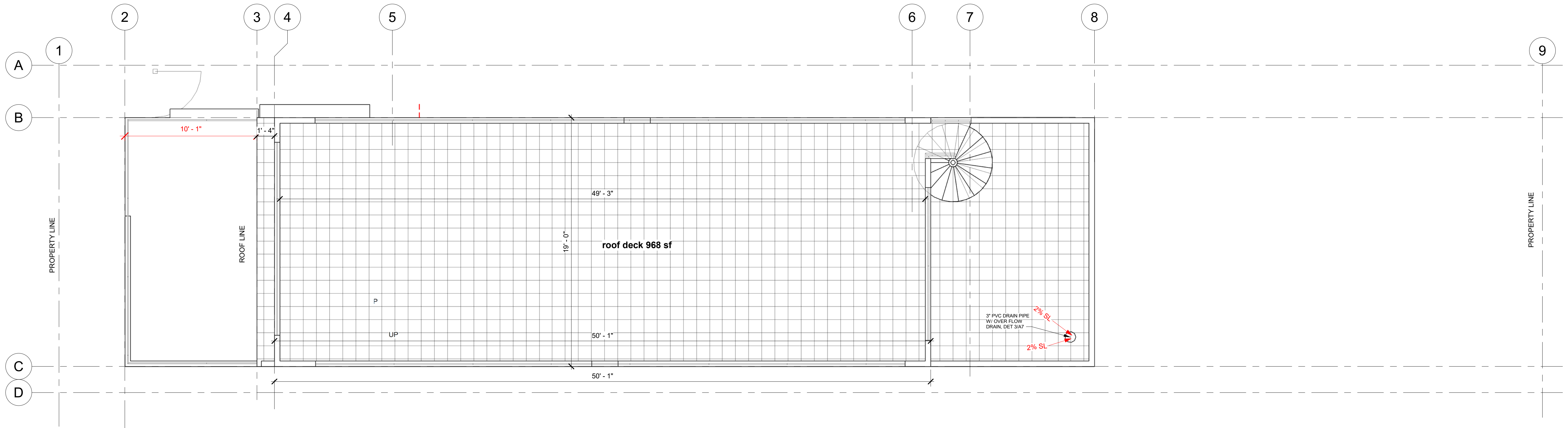

① ROOF  
1/4" = 1'-0"

**RESTRICTIVE NOTICE**  
THESE DESIGNS, DRAWINGS & SPECIFICATION ARE THE EXCLUSIVE PROPERTY OF FL DESIGN GROUP AND ALL INFORMATION SHOWN IS CONFIDENTIAL TO ALL RECIPIENTS AND NO PART OF THESE DRAWINGS CAN BE COPIED, TRANSFERRED, OR REPRODUCED WITHOUT WRITTEN CONSENT OF FL DESIGN GROUP.

Project No: 71-01  
Date: 03-25-2024

ROOF PLAN

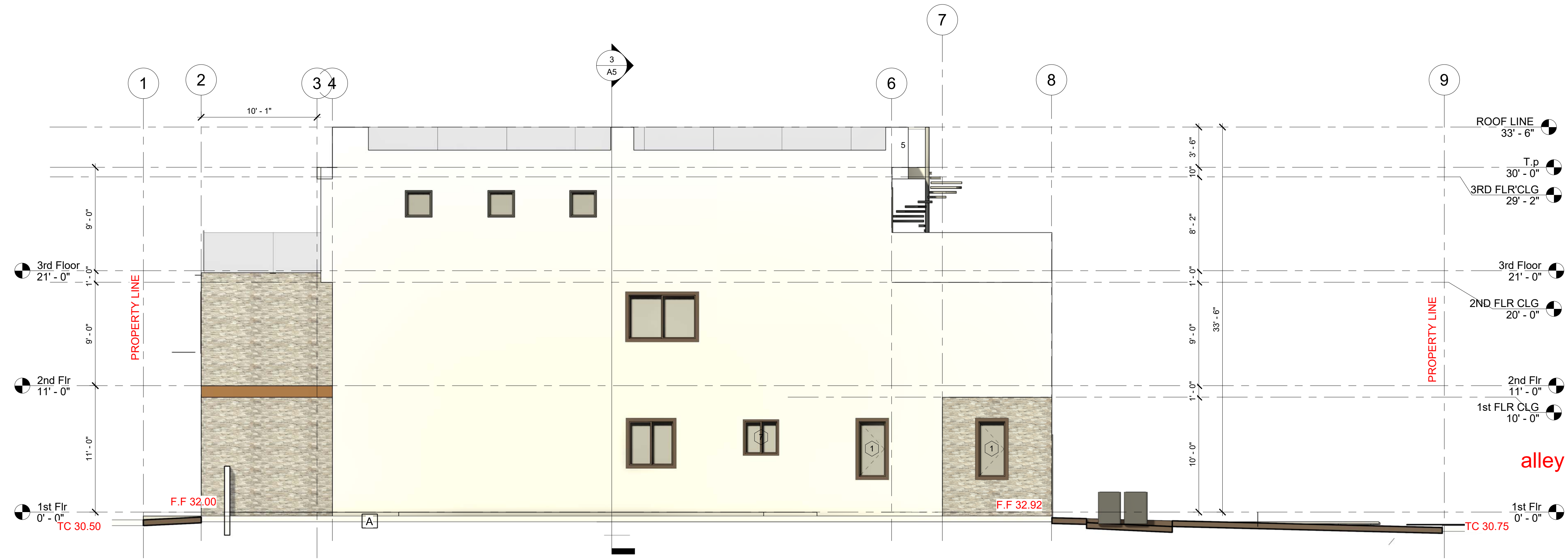

② RIGHT ELEVATION  
3/16" = 1'-0"

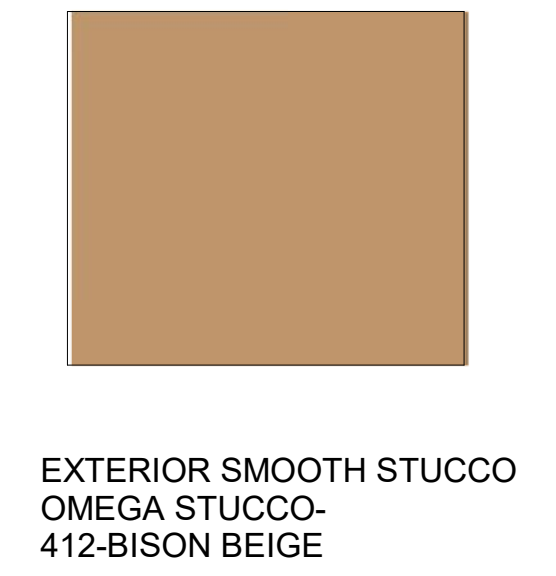

EXTERIOR SMOOTH STUCCO  
OMEGA STUCCO-  
412-BISON BEIGE

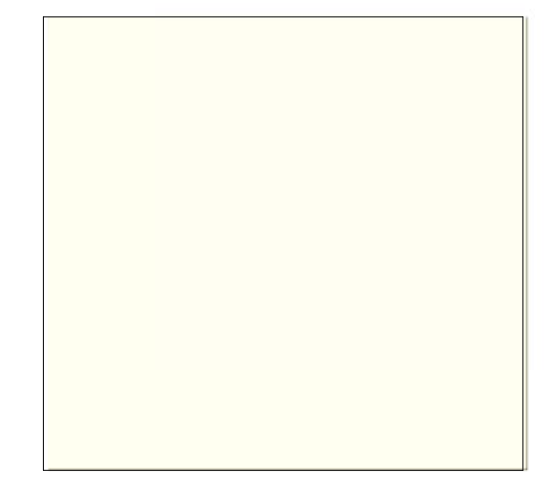

EXTERIOR SMOOTH STUCCO  
OMEGA STUCCO- COCONUT COLOR



CUT STONE  
CRYSTAL SILVER WHITE  
6"X24" LEDGER PANEL

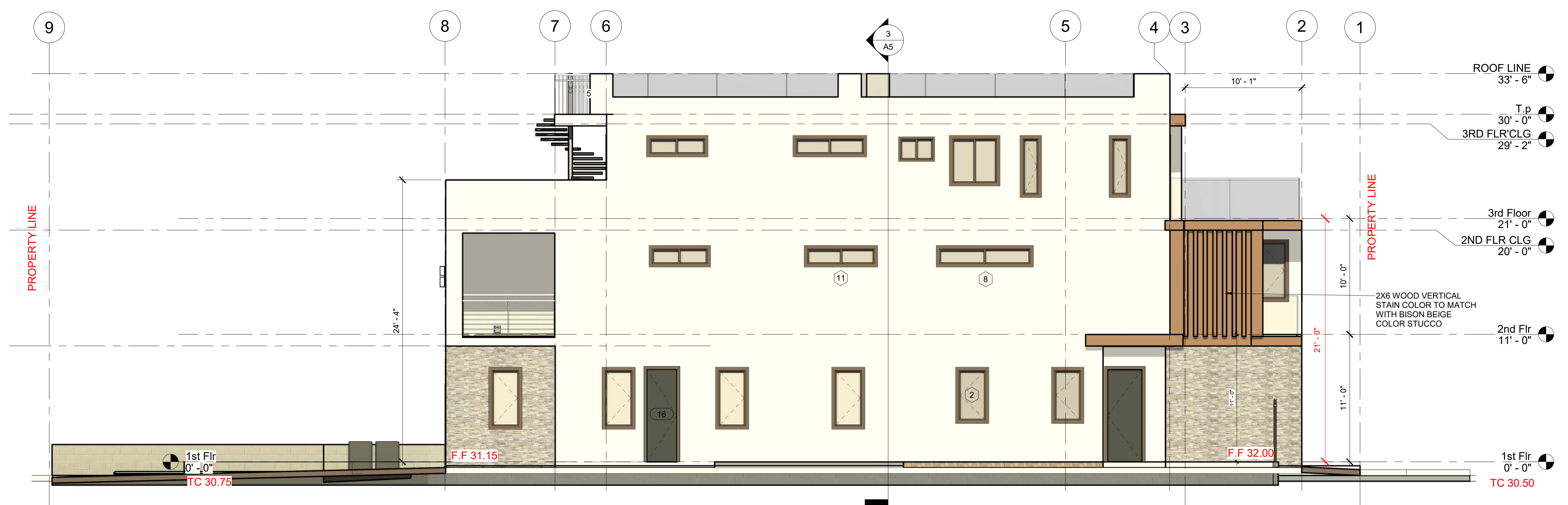

④ LEFT ELEVATION  
3/16" = 1'-0"

**RESTRICTIVE NOTICE**  
THESE DESIGNS, DRAWINGS & SPECIFICATION ARE THE EXCLUSIVE PROPERTY OF FL DESIGN GROUP AND ALL INFORMATION SHOWN IS CONFIDENTIAL TO ALL RECIPIENTS AND NO PART OF THESE DRAWINGS CAN BE COPIED, TRANSFERRED, OR REPRODUCED WITHOUT WRITTEN CONSENT OF FL DESIGN GROUP.

Project No: 71-01  
Date: 03-25-2024

2X6 WOOD VERTICAL STAIN COLOR TO MATCH WITH BISON BEIGE COLOR STUCCO

ELEVATION



1 FRONT ELEVATION  
1/4" = 1'-0"

2 REAR ELEVATION2  
1/4" = 1'-0"

- 1- PROVIDE TWO LAYER OF GRADE D PAPER OVER ALL WOOD BASE SHEATHING
- 2- PROVIDE # 43 FELT ROOF UNDERLAYMENT BETWEEN TILE AND ROOF SHEATHING
- 3- INSTALLATION OF ROOF SHALL BE IN ACCORDANCE WITH MANUFACTURE'S SPECIFICATION

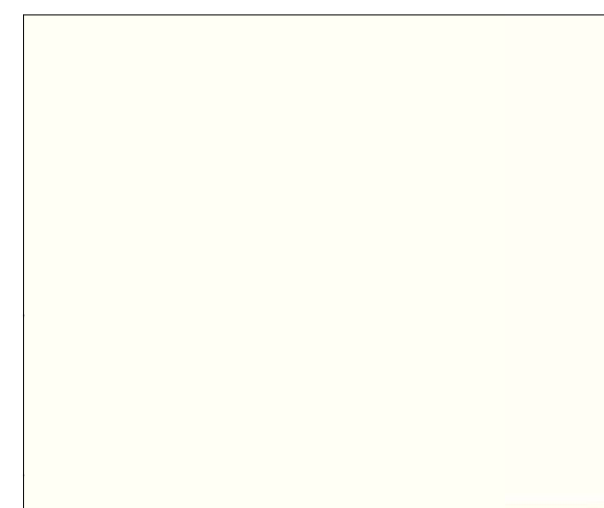

EXTERIOR SMOOTH STUCCO  
OMEGA STUCCO- IVORY WHITE



CUT STONE  
CRYSTAL SILVER WHITE  
6\"/>



EXTERIOR SMOOTH STUCCO  
OMEGA STUCCO-  
412-BISON BEIGE

WINDOW SCHEDULE					
Type Mark	Width	R.O. Height	Family	From Room: Name	Comments
1	2'-6"	5'-0"	Casement with Trim	3 CAR GARAGE	
1	2'-6"	5'-0"	Casement with Trim	3 CAR GARAGE	
1	2'-6"	5'-0"	Casement with Trim		
1	2'-6"	5'-0"	Casement with Trim		
1	2'-6"	5'-0"	Casement with Trim		
2	2'-6"	4'-6"	Casement with Trim	KITCHEN	11.3 SF EGRESS OPENING
2	2'-6"	4'-6"	Casement with Trim	KITCHEN	11.3 SF EGRESS OPENING
3	3'-0"	2'-0"	Sliding Window	shwr	TEMP GLASS
4	1'-6"	5'-0"	Casement with Trim	BED RM 1	13.7 SD EGRESS OPENING
4	1'-6"	5'-0"	Casement with Trim	BED RM 1	13.7 SD EGRESS OPENING
5	2'-4"	2'-4"	Fixed	DEN	TEMP GLASS
5	2'-4"	2'-4"	Fixed	DEN	TEMP GLASS
5	2'-4"	2'-4"	Fixed	DEN	10 SF EGRESS OPENING
5	2'-6"	5'-0"	Casement with Trim	BALCONY	
6	4'-0"	4'-0"	Sliding Window	LAUNDRY	TEMP GLASS
6	4'-0"	4'-0"	Sliding Window	shwr	TEMP GLASS
7	3'-0"	3'-0"	Sliding Window	H.C BATH	TEMP GLASS
8	8'-0"	1'-6"	Sliding Window	shwr	TEMP GLASS
9	5'-0"	1'-6"	Sliding Window	BATH	TEMP GLASS
9	6'-0"	4'-0"	Sliding Window	LOFT	
9	5'-0"	1'-6"	Sliding Window	BATH	TEMP GLASS
10	2'-0"	5'-0"	Casement with Trim	BED RM 1	
10	2'-0"	5'-0"	Casement with Trim	BED RM 1	
10	2'-0"	5'-0"	Casement with Trim	BED RM 1	
11	6'-0"	1'-6"	Sliding Window	WIC	11.3 SF EGRESS OPENING
11	6'-0"	1'-6"	Sliding Window	WIC	

DOOR SCHEDULE							
Mark	Door Width	Door Height	Family	From Room: Name	Door Material	Comments	Level
15	16'-0"	7'-0"	Garage_Door	3 CAR GARAGE	METAL	ROLL UP DOOR	1st Flr
16	2'-8"	8'-0"	Single-Flush	3 CAR GARAGE			1st Flr
17	2'-2"	6'-8"	Single-Flush	BATH			2nd Flr
18	2'-4"	7'-0"	Single-Glass 1	shwr			2nd Flr
19	4'-0"	7'-0"	Bifold-2 Panel	LAUNDRY			1st Flr
20	3'-0"	8'-0"	Single-Flush	BED RM			2nd Flr
23	8'-0"	7'-0"	Sliding Door	DECK		TEMP GLASS	3rd Floor
24	2'-6"	7'-0"	Single-Flush	BATH			3rd Floor
28	4'-0"	7'-0"	Bifold-2 Panel	LAUNDRY			1st Flr
30	2'-0"	6'-8"	Single-Flush	BATH			3rd Floor
32	6'-0"	7'-0"	Sliding Door	DECK			3rd Floor
35	3'-0"	8'-0"	Single-Flush	H.C BATH			1st Flr
36	3'-0"	8'-0"	Single-Flush	3 CAR GARAGE			1st Flr
38	3'-0"	8'-0"	Single-Glass 1	BALCONY			2nd Flr
39	3'-0"	8'-0"	Single-Flush	BED RM 1			2nd Flr
40	3'-0"	8'-0"	Single-Flush	DEN			3rd Floor
42	11'-0"	8'-0"	RFAM20352_Bi-Fold-Sliding-Door	OFFICE AREA		TEMP GLASS	1st Flr
44	3'-0"	8'-0"	Single-Flush				1st Flr
45	2'-6"	8'-0"	Single-Flush	BATH			2nd Flr
46	4'-0"	6'-8"	Sliding Door	BATH			2nd Flr
47	6'-0"	8'-0"	Sliding Door	DECK		TEMP GLASS	2nd Flr
48	2'-2"	6'-8"	Single-Flush	BATH			3rd Floor
49	2'-4"	7'-0"	Single-Glass 1	shwr			3rd Floor
50	5'-0"	8'-0"	Double-Panel	DEN			3rd Floor
51	2'-8"	7'-0"	Single-Flush	DEN			3rd Floor
52	2'-0"	6'-8"	Single-Flush	WIC			2nd Flr

**RESTRICTIVE NOTICE**  
THESE DESIGNS, DRAWINGS & SPECIFICATION ARE THE EXCLUSIVE PROPERTY OF FL DESIGN GROUP AND ALL INFORMATION SHOWN IS CONFIDENTIAL TO ALL RECIPIENTS AND NO PART OF THESE DRAWINGS CAN BE COPIED, TRANSFERRED, OR REPRODUCED WITHOUT WRITTEN CONSENT OF FL DESIGN GROUP

Project No: 71-01  
Date: 03-25-2024

ELEVATION

A3.2